

Heavy Duty Compression Load Cell

FEATURES

- Capacities 50–150 ton
- Ideal for multi-cell applications
- Compact, economical, column design
- Hermetically sealed to IP68
- 6-Wire (sense) circuit
- Stainless steel housing as standard

APPLICATIONS

- Hopper and tank weighing
- Truck weighbridges

DESCRIPTION

Model 122 is a heavy duty general purpose compression load cell particularly well suited for hopper and tank weighing and many other large scale industrial applications, including weighbridges for truck weighing.

The simple, compact column design and rugged hermetically sealed construction of the Model 122 load cell assures its long-term life in all types of field installations.



ATEX

The Model 122 load cell is often used in multi-cell installations, therefore its standard output tolerance is within 0.1%.

The two additional sense wires feed back the voltage reaching the load cell. Complete compensation of changes in lead resistance due to temperature change and/or cable extension, is achieved by feeding this voltage into the appropriate electronics.

OUTLINE DIMENSIONS in millimeters

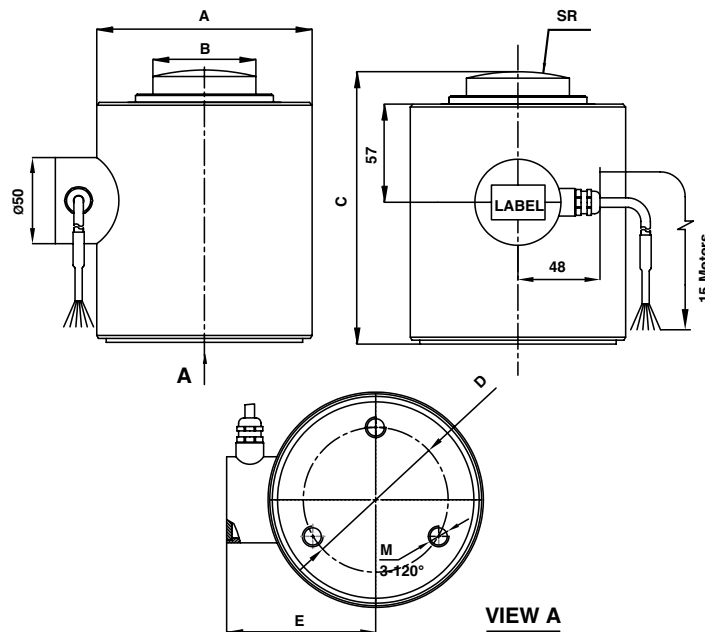

CAPACITY	A	B	C	D	E	M	SR
50T	Ø88	Ø45	122	Ø50	69	M10	SR35
100T, 150T	Ø125	Ø59.8	158	Ø84	86.5	M12	SR120

Heavy Duty Compression Load Cell

SPECIFICATIONS				
PARAMETER	VALUE			UNIT
Rated capacity – R.C. (E_{max})	50	100	150	ton
NTEP/OIML accuracy class	Non-Approved ⁽¹⁾			
Maximum no. of intervals (n)	2000			
$Y = E_{max}/V_{min}$	2000			
Rated output – R.O.	1.5		2	mV/V
Rated output tolerance	0.0015			±mV/V
Zero balance	0.015		0.02	±mV/V
Zero return, 30 min.	0.030			±% of applied load
Total error (per OIML R60)	0.030			±% of rated output
Temperature effect on zero	0.03			±% of rated output/°C
Temperature effect on output, unbalanced	0.0080 ⁽²⁾			±% of load/°C
Temperature range, compensated	5 to +45			°C
Temperature range, safe	-20 to +60			°C
Maximum safe central overload	150			% of R.C.
Ultimate central overload	200			% of R.C.
Excitation, recommended	10			VDC or VAC RMS
Excitation, maximum	15			VDC or VAC RMS
Input impedance	670±15	1270±20	1350±30	Ω
Output impedance	600±5	1205±5	1205±5	Ω
Insulation resistance	>2000			MΩ
Cable length	15			m
Cable type	6 wire, braided, PVC, single floating screen			Standard
Construction	Stainless steel housing, plated alloy steel sensor			
Environmental protection	IP68			

⁽¹⁾ Typical 80% utilization

⁽²⁾ Balanced span compensation is available upon request

All specifications subject to change without notice.

WIRING SCHEMATIC DIAGRAM
(Unbalanced bridge configuration)

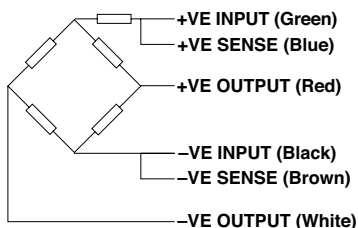

Disclaimer

ALL PRODUCTS, PRODUCT SPECIFICATIONS AND DATA ARE SUBJECT TO CHANGE WITHOUT NOTICE.

Vishay Precision Group, Inc., its affiliates, agents, and employees, and all persons acting on its or their behalf (collectively, "Vishay Precision Group"), disclaim any and all liability for any errors, inaccuracies or incompleteness contained herein or in any other disclosure relating to any product.

The product specifications do not expand or otherwise modify Vishay Precision Group's terms and conditions of purchase, including but not limited to, the warranty expressed therein.

Vishay Precision Group makes no warranty, representation or guarantee other than as set forth in the terms and conditions of purchase. **To the maximum extent permitted by applicable law, Vishay Precision Group disclaims (i) any and all liability arising out of the application or use of any product, (ii) any and all liability, including without limitation special, consequential or incidental damages, and (iii) any and all implied warranties, including warranties of fitness for particular purpose, non-infringement and merchantability.**

Information provided in datasheets and/or specifications may vary from actual results in different applications and performance may vary over time. Statements regarding the suitability of products for certain types of applications are based on Vishay Precision Group's knowledge of typical requirements that are often placed on Vishay Precision Group products. It is the customer's responsibility to validate that a particular product with the properties described in the product specification is suitable for use in a particular application.

No license, express, implied, or otherwise, to any intellectual property rights is granted by this document, or by any conduct of Vishay Precision Group.

The products shown herein are not designed for use in life-saving or life-sustaining applications unless otherwise expressly indicated. Customers using or selling Vishay Precision Group products not expressly indicated for use in such applications do so entirely at their own risk and agree to fully indemnify Vishay Precision Group for any damages arising or resulting from such use or sale. Please contact authorized Vishay Precision Group personnel to obtain written terms and conditions regarding products designed for such applications.

Product names and markings noted herein may be trademarks of their respective owners.