

Stainless Steel, Welded Seal Shear Beam Load Cell

FEATURES

- Rated capacities of 1000 to 20,000 pounds
- Stainless steel, welded seal construction
- Trade certified for NTEP Class III L 10000 and III 5000 divisions and OIML R-60 3000 divisions
- Hostile or clean environment
- *Sensorgage™* sealed to IP67 standards
- Factory Mutual System Approved for Classes I, II, III; Divisions 1 and 2; Groups A through G. Also, non-incendive ratings (No barriers!)
- **Optional**
 - Integral conduit adaptor with teflon jacketed cable available

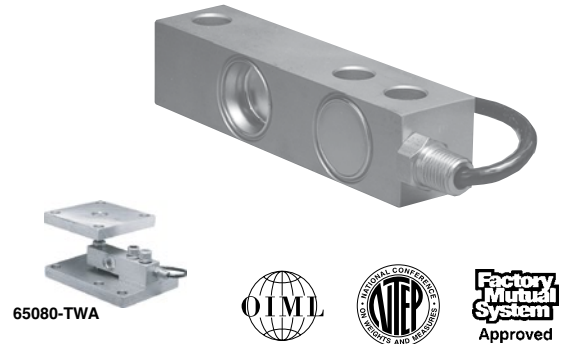

APPLICATIONS

- Hostile environments: food and beverage processing, chemical and plastics processing, pharmaceutical and biomedical processing
- Tank, bin and hopper weighing
- Batching, blending and mixing systems

DESCRIPTION

Model 65083 provides the weighing industry with excellent protection necessary for today's hostile environments in an economical low profile range suitable for platform scale manufacture.

Its low profile and all welded sealing combined with high accuracy makes this load cell ideally suited for low

profile platforms, pallet truck weighers, tanks and silos. The guide slots incorporated into the upper and lower mounting faces enable manufacturers to easily position the load cell.

Hermetically sealed against moisture, the construction of the model 65083 in combination with a polyurethane dual shielded cable, enables continuous operation in harsh environments while maintaining a high operating specification.

The two additional sense wires feed back the voltage reaching the load cell. Complete compensation of changes in lead resistance due to temperature change and/or cable extension, is achieved by feeding this voltage into the appropriate electronics.

OUTLINE DIMENSIONS in inches

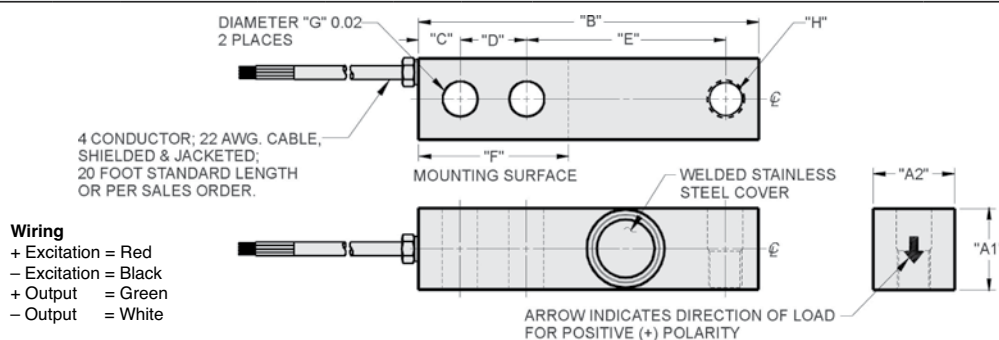

CAPACITY	A1	A2	B	C	D	E	F	G	H	DEFLECTION	WEIGHT
1k-4k	1.22	1.22	5.12	0.62	1.00	3.00	2.25	0.53	1/2-20 UNF-2B, Ø0.53 x 0.61 DEEP C'BORE	0.008-0.026	4.0
5k-SE*	1.22	1.22	5.12	0.62	1.00	3.00	2.25	0.53	1/2-20 UNF-2B, Ø0.53 x 0.61 DEEP C'BORE	0.008-0.026	4.0
5k-10k	1.50	1.50	6.75	0.75	1.50	3.75	3.00	0.78	3/4-16 UNF-2B, Ø0.78 x 0.75 DEEP C'BORE	0.030-0.055	6.5
15k-20k	2.00	2.00	8.75	1.00	2.00	4.88	4.00	1.06	1-14 UNS-2B, Ø1.06 x 1.00 DEEP C'BORE	0.025-0.032	9.0

Capacities are in pounds. Deflection is $\pm 10\%$. Certified drawings are available.
* SE denotes "Small Envelope". A 5k capacity is available in the 1k/4k dimensional envelope.

Stainless Steel, Welded Seal Shear Beam Load Cell

SPECIFICATIONS					
PARAMETER	VALUE				UNIT
Rated capacity—R.C. (E_{max})	1k, 1.5k, 2.5k, 4k, 5k, 10k, 15k, 20k ⁽¹⁾ 500 kg, 750 kg, 1T, 2T, 5T ⁽¹⁾				lbs kg/metric tons
NTEP/OIML accuracy class	NTEP III	NTEP IIIIL	Standard	OIML R60	
Maximum no. of intervals (n)	5000 single	10000 multiple		3000 ⁽¹⁾	
$Y = E_{max}/V_{min}$	NTEP Cert. No. 98-175				8333
Rated output—R.O.	2.0	2.0	3.0	2.0	mV/V
Rated output tolerance	0.25				±% mV/V
Zero balance	1.0				±% FSO
Combined error	0.02	0.02	0.03	0.02	±% FSO
Non-repeatability	0.01				±% FSO
Creep error (30 minutes)	0.025	0.03	0.03	0.017	±% FSO
Temperature effect on zero	0.0010	0.0010	0.0015	0.0010	±% FSO/°F
Temperature effect on output	0.0008	0.0008	0.0008	0.0007	±% of load/°F
Compensated temperature range	14 to 104 (–10 to 40)				°F (°C)
Operating temperature range	0 to 150 (–18 to 65)				°F (°C)
Storage temperature range	–60 to 185 (–50 to 85)				°F (°C)
Sideload rejection ratio	500:1				
Safe sideload	100				% of R.C.
Maximum safe central overload	150				% of R.C.
Ultimate central overload	300				% of R.C.
Excitation, recommended	10				VDC or VAC RMS
Excitation, maximum	15				VDC or VAC RMS
Input impedance	343–357				Ω
Output impedance	349–355				Ω
Insulation resistance at 50 VDC	>1000				MΩ
Material	Stainless steel				
Environmental protection	IP68				
Recommended torque	All capacities up to 5000 kg–136.0 5000 kg–205.0				N*m

Notes

- ⁽¹⁾ OIML approval 1–10k lbs and 500–5000 kg only
 NTEP approval 1–10k lbs only (kg/metric capacities are not approved)
 FSO—Full Scale Output
 All specifications subject to change without notice.

Disclaimer

ALL PRODUCTS, PRODUCT SPECIFICATIONS AND DATA ARE SUBJECT TO CHANGE WITHOUT NOTICE.

Vishay Precision Group, Inc., its affiliates, agents, and employees, and all persons acting on its or their behalf (collectively, "Vishay Precision Group"), disclaim any and all liability for any errors, inaccuracies or incompleteness contained herein or in any other disclosure relating to any product.

The product specifications do not expand or otherwise modify Vishay Precision Group's terms and conditions of purchase, including but not limited to, the warranty expressed therein.

Vishay Precision Group makes no warranty, representation or guarantee other than as set forth in the terms and conditions of purchase. **To the maximum extent permitted by applicable law, Vishay Precision Group disclaims (i) any and all liability arising out of the application or use of any product, (ii) any and all liability, including without limitation special, consequential or incidental damages, and (iii) any and all implied warranties, including warranties of fitness for particular purpose, non-infringement and merchantability.**

Information provided in datasheets and/or specifications may vary from actual results in different applications and performance may vary over time. Statements regarding the suitability of products for certain types of applications are based on Vishay Precision Group's knowledge of typical requirements that are often placed on Vishay Precision Group products. It is the customer's responsibility to validate that a particular product with the properties described in the product specification is suitable for use in a particular application.

No license, express, implied, or otherwise, to any intellectual property rights is granted by this document, or by any conduct of Vishay Precision Group.

The products shown herein are not designed for use in life-saving or life-sustaining applications unless otherwise expressly indicated. Customers using or selling Vishay Precision Group products not expressly indicated for use in such applications do so entirely at their own risk and agree to fully indemnify Vishay Precision Group for any damages arising or resulting from such use or sale. Please contact authorized Vishay Precision Group personnel to obtain written terms and conditions regarding products designed for such applications.

Product names and markings noted herein may be trademarks of their respective owners.